

# HOG PUMP

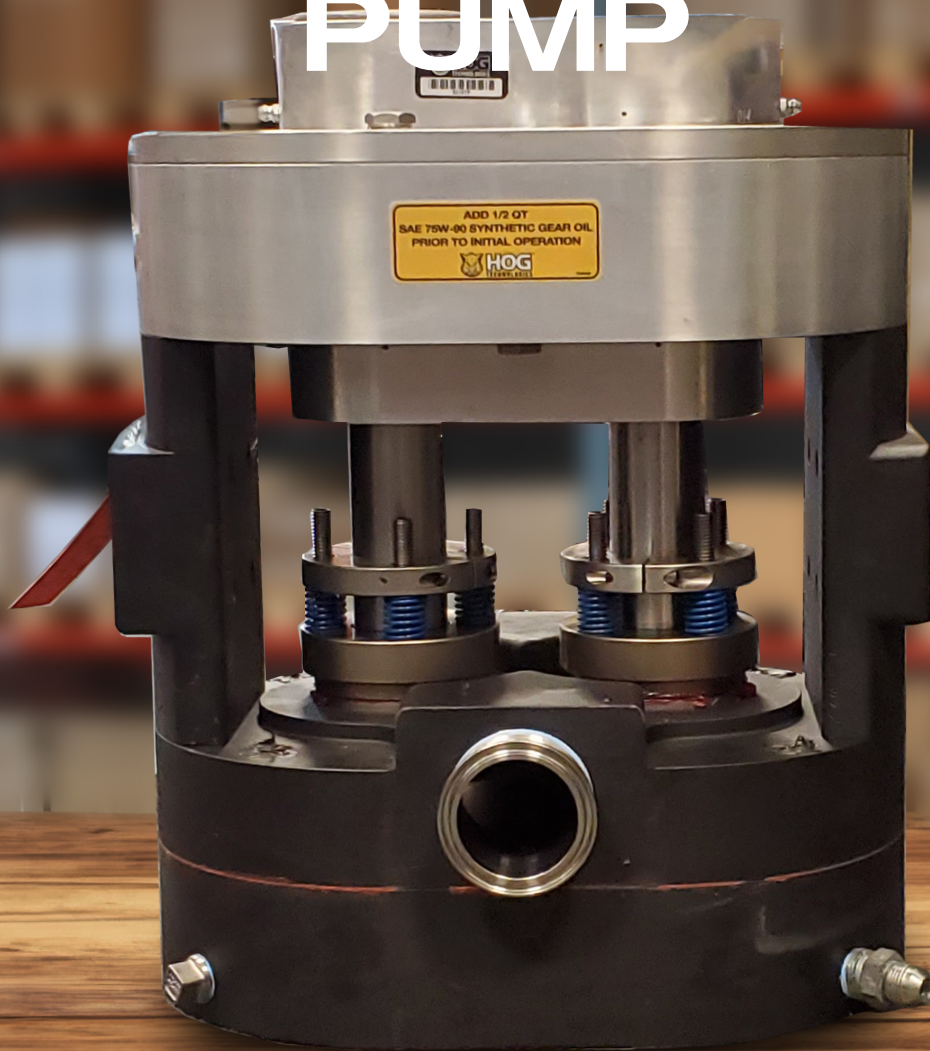

**SPECIALLY ENGINEERED FOR PUMPING  
THERMOPLASTIC**

**REBUILD COST LESS THAN 1/2 OF A REPLACEMENT  
PUMP**

**REBUILDABLE IN PLACE; NO NEED TO REMOVE IT  
FROM PLUMBING**





# HOG PUMP

## PAVEMENT MARKING EQUIPMENT

### ADVANTAGES

- Rebuildable in place (no need to remove from plumbing)
- Easily adapts to any existing configuration
- Delivers even flow producing excellent starts and stops with straight even edges
- Weight: 200 lbs (90.71 kg) lighter than competitive pumps
- 33" (83.82 cm) shorter than competitive pumps
- Engineered cavity clearances to minimize wear from glass bead intermix of thermoplastic
- Hardened wear surfaces
- Rebuild cost is less than 1/2 the cost of a replacement pump
- Oil-jacketed thermo cavity
- Constant compression mechanical shaft seals
- Engineered to pump thermoplastic at higher pressures required by spray as well as lower demand pressures for ribbon and transfer

### SPECIFICATIONS

#### PUMP

**INLET/OUTLET PORT:** 2" (5 cm) NPT  
**MAX RPM:** 250  
**MAX OPERATING TEMPERATURE:** 500°F (260°C)  
**MAX INPUT TORQUE:** 3,043 in/lbs (244 Nm)  
**MAX PSI:** 100

#### HYDRAULICS

**DISPLACEMENT:** 140cc / rev  
**OUTPUT:** Shaft 1" (2.54 cm) spline  
**COUPLING:** 1" (2.54 cm) Internal spline direct coupled  
**HYDRAULIC PRESSURE:** 2,250 psi (155 bar)  
**OIL-JACKETING PORT:** 1/2" (1.27 cm) NPT  
**OVERALL DIMENSIONS:** 25.5" H x 13" W x 9" D (25.5 cm H x 33 cm W x 22.86 cm D)  
**FLOW RATE:** 180 lbs (81.6 kg) /min @150 RPM  
 300 lbs (136 kg) /min @300 RPM  
 550 lbs (249.4 kg) /min @450 Max RPM

### ADAPTOR KIT

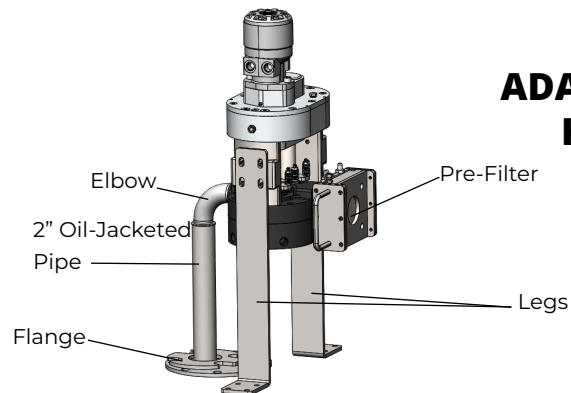

### THE HOG DIFFERENCE

- 98% of spare parts orders are shipped on the same day they are received, resulting in minimal downtime.
- Hog Tech University - Our New Learning Management System is the perfect place for your team members to receive certification and on-going training. Certified Operators maximize the productivity of your truck while maintaining the highest levels of safety at the lowest operating costs.
- Hog Technologies has a team of engineers and over 100 years of combined real-world experience to create the world's best solutions in every product we manufacture.
- 24/7/365 customer support is available with Certified Technicians within 10 minutes in multiple languages.

### EASILY REBUILDABLE

